

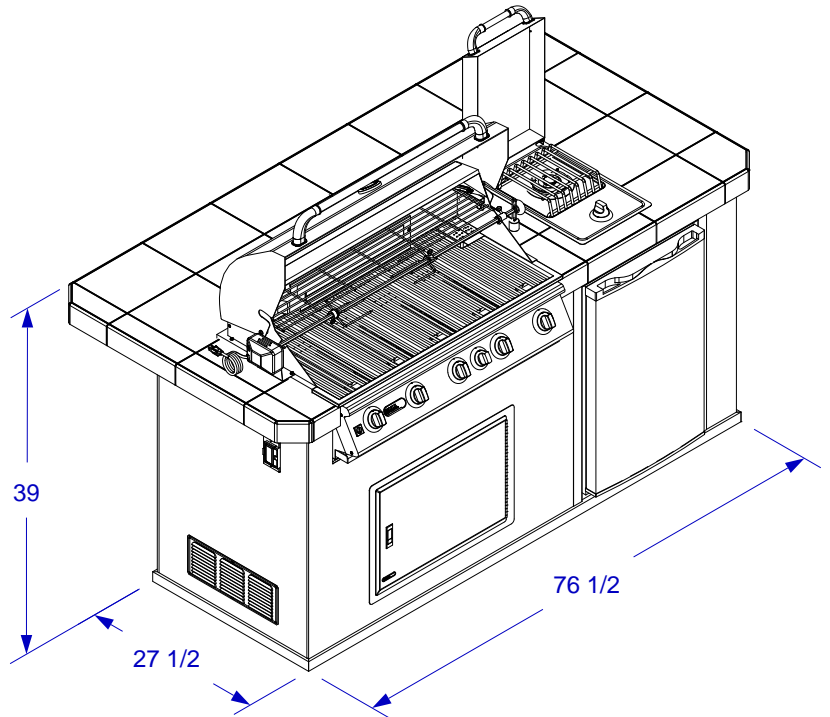

**POWER Q ISLAND**  
**W/ 43" TOP, BRAHMA**  
**GRILL & FRIDGE**  
**SPEC SHEET**

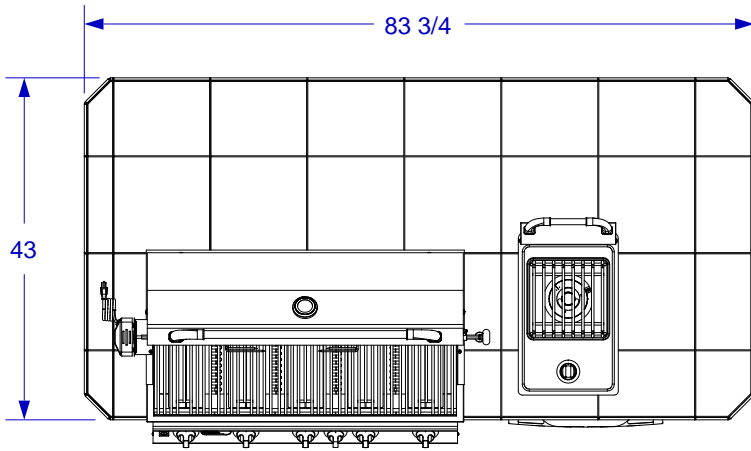

ISOMETRIC VIEW



TOP VIEW

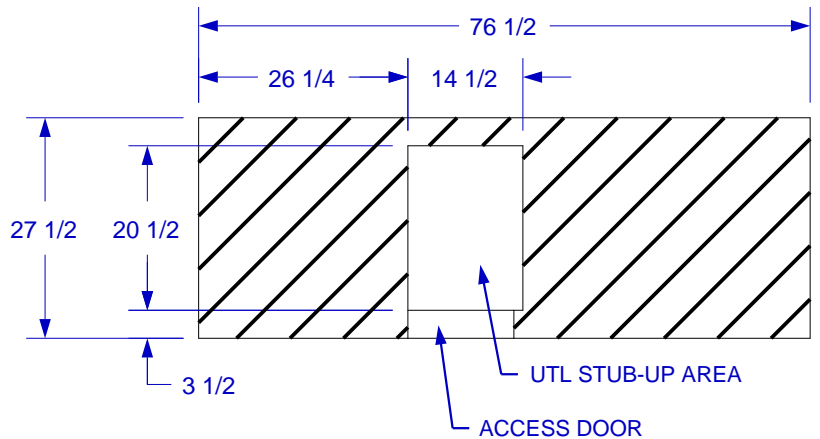

STUB-UP DIAGRAM  
 (SEE NOTE #2)

**NOTES:**

1. FOR ROCK FINISHES, ADD 1 1/2" ON ALL BASE SIDES.
2. 6" MAX HEIGHT ON ALL STUB-UPS.
3. SHOWN WITH OPTIONAL 5-BURNER BRAHMA GRILL.
4. SCALE: 1/2" = 1'-0"
5. REVISION: 10/2009